



The Rotating Floor Crane Series

Boom rotates 200° to either side with full load. Useful in tight spaces where the crane itself cannot turn.

Adjustable outrigger provides stability for quick and safe side loading.

Equipped with heavy duty roller bearing wheels, manual pump, adjustable chain and hook, safety pins and guide handle

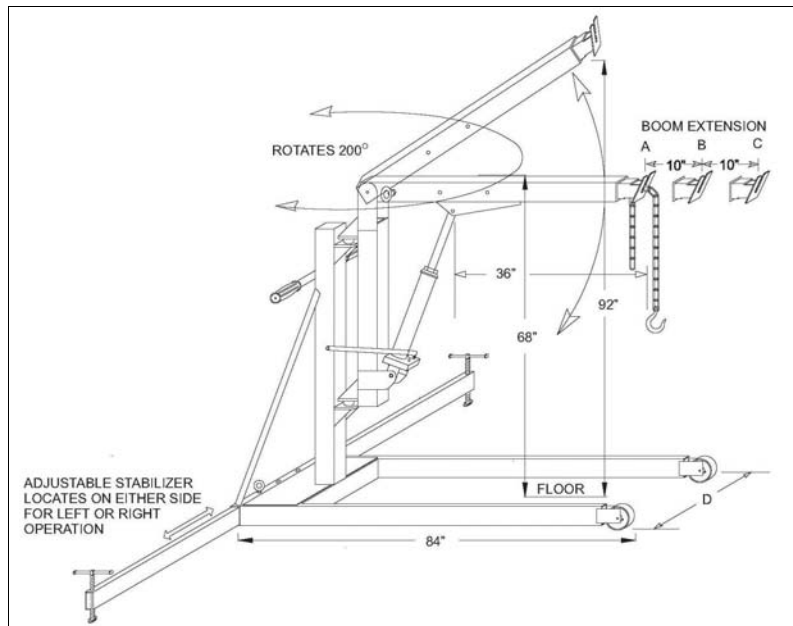

ROTATING FLOOR CRANE SPECIFICATIONS

MODELS	SHIPPING WEIGHT LBS	CAPACITY A LBS	CAPACITY B LBS	CAPACITY C LBS	WIDTH D INCHES	WHEEL DIA. F/R	REPLACEMENT PUMP	PUMP (SEALS) WEAR KIT
SC-10	450	1,000	770	320	36	5/4	LRJ3-3	LRJ3-3RK
SC-20	550	2,000	1,280	520	36	5/4	LRJ3-3	LRJ3-3RK
SC-30	690	3,000	1,500	800	40	8/6	LRJ5-3	LRJ5-3RK

If your capacities are not shown with our standard designs, custom designs can be engineered to satisfy specific needs.