

# Reverse Boom Floor Cranes

## RC Series



Reverse Boom Floor Cranes



### REVERSE BOOM FLOOR CRANES

Useful for supplying materials to working areas that are not serviced by overhead cranes. The counter weight design allows to place the crane close to the item being lifted without obstruction.

Equipped with roller bearing wheels, swivel wheel foot brakes, manual pump, adjustable chain and hook, safety pins, push handle and counterweight. RC-10 & RC-20 fold for storage or transportation.

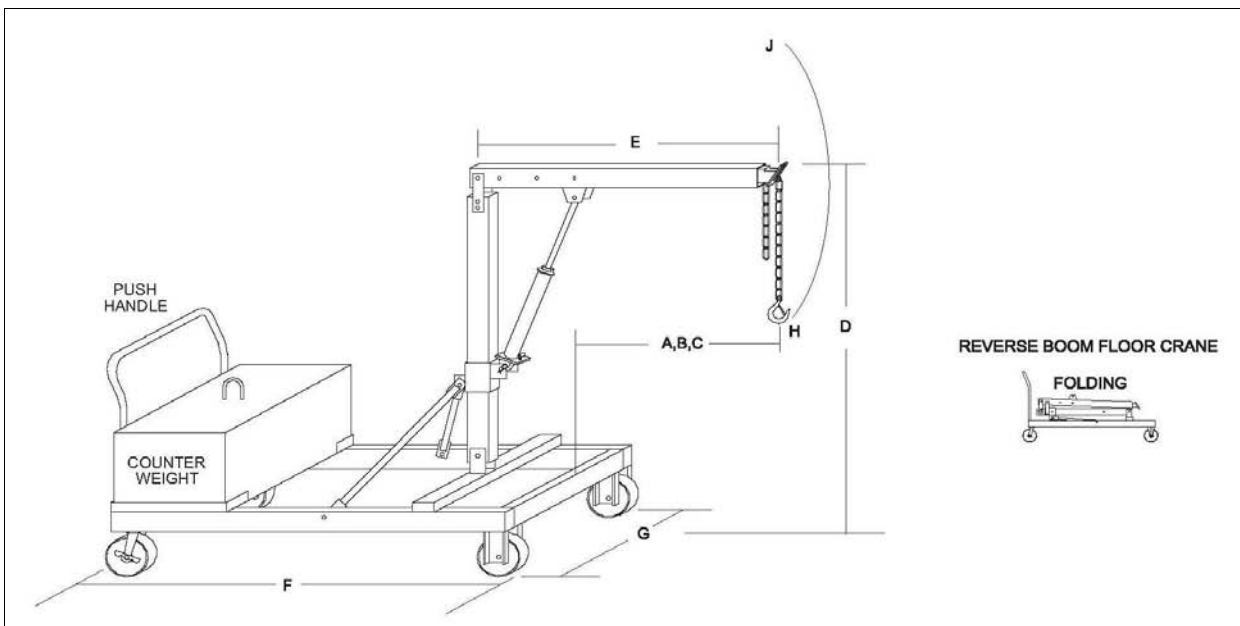

### REVERSE BOOM FLOOR CRANE SPECIFICATIONS

MODELS	CAPACITY A LBS	CAPACITY B LBS	CAPACITY C LBS	COUNTER WEIGHT LBS	SHIPPING WEIGHT LBS	REPLACEMENT PUMP	PUMP (SEALS) WEAR KIT
RC-10	1,000	770	650	650	1050	LRJ3-3	LRJ3-3RK
RC-20	2,000	1,280	1000	1300	1750	LRJ3-3	LRJ3-3RK
RC-30	3,000	2,000	1500	1950	2450	LRJ5-3	LRJ5-3RK

MODEL	REACH A INCHES	REACH B INCHES	REACH C INCHES	MAST D INCHES	BOOM E INCHES	BASE F INCHES	BASE G INCHES	MAX LOW H	MAX HIGH J
ALL MODELS	36	43	50	78	57	72	30	32	105

If your capacities are not shown with our standard designs, custom designs can be engineered to satisfy specific needs.

For informations on this product, please contact Jason Pietroniro Tel.: 514-573-0267  
 3421 Industriel Blvd / Laval, Qc / Canada H7L 4S3 / 1-888-663-8122 / 450-663-8122 / Fax: 450-663-6797  
[www.tramac.com](http://www.tramac.com)

