

Rockbreaker Booms

TS Series

for breakers from 750 through 2000 ft. lbs.



Unmatched reliability when the job calls for breaking medium hard rock with breakers between 750 and 2,000 ft. lbs.

BUILT-IN RELIABILITY: Tramac's all new TS series of Rockbreaker Booms bring you unmatched reliability in heavy-duty designs that are also light in weight.

BREAKERS UP TO 2000 ft. lbs: The new TS series rounds out our line-up with duty levels designed to carry breakers from 750 through 2,000 ft. lbs., for applications working in medium hard rock.

INCREASED SAFETY AND PRODUCTION: Increase safety around your primary. Eliminate the need for a worker to enter the area. Increase your up-time. Provide a steady flow of materials. Break rock, pull, poke and stir material. Reach back into the hopper and work down along the feeder area and into the crusher with smooth precision of control.

PROPER SET-UP: The key to long equipment life and top production is to start with the boom placed in exactly the right spot. When working in your target area, a boom is positioned in its "sweet spot" when it is arched symmetrically and the cylinders are in their mid positions. Tramac engineering will gladly work with you to find the right boom base position so you can reach the areas of top priority.

ADVANCED CONTROLS:

These systems are optionally equipped with the very latest electro-hydraulic joystick operated controls. Each function is supplied a precisely metered amount of hydraulic power, with reliefs set to instantly protect from dangers that can arise when working in conjunction with other moving equipment. In some cases, manually activated lever controls are preferred. Indicate your requirements at time of order.

OVERSIZED PINS, HEAVY DUTY CYLINDERS: For equipment safety and long life, boom and cylinder pins are made with diameters that exceed requirements. Cylinders are high strength, heavy duty designs with oversized rods and built-in cushioning for smooth functioning.



TS Series Rockbreaker Booms

For dimensions and specifications, see reverse side.

TS Booms: Approximate Working Ranges

BOOM		TS14				TS16				TS18				TS20			
		Breaker		SC28	SC36	300	700	SC28	SC36	300	700	SC28	SC36	300	700	SC28	SC36
A	ft-in	1'-8"	2'-0"	3'-0"	4'-0"	4'-2"	4'-6"	5'-6"	6'-6"	2'-2"	2'-6"	3'-6"	4'-3"	2'-10"	3'-2"	4'-2"	5'-6"
	mm	508	609	914	1,219	1,263	1,369	1,676	1,981	660	762	1,067	1,295	864	905	1,270	1,676
B	ft-in	8'-0"	8'-0"	8'-0"	8'-0"	8'-6"	8'-6"	8'-6"	8'-6"	10'-0"	10'-0"	10'-0"	10'-0"	10'-6"	10'-6"	10'-6"	10'-6"
	mm	2,438	2,438	2,438	2,438	2,591	2,591	2,591	2,591	3,048	3,048	3,048	3,048	3,200	3,200	3,200	3,200
C	ft-in	14'-0"	14'-0"	14'-0"	14'-0"	16'-0"	16'-0"	16'-0"	16'-0"	18'-0"	18'-0"	18'-0"	18'-0"	20'-0"	20'-0"	20'-0"	20'-0"
	mm	4,267	4,267	4,267	4,267	4,877	4,877	4,877	4,877	5,486	5,486	5,486	5,486	6,096	6,096	6,096	6,096
D	ft-in	17'-8"	18'-0"	19'-0"	20'-3"	20'-2"	20'-6"	21'-6"	22'-3"	21'-10"	22'-0"	23'-0"	24'-3"	24'-8"	25'-0"	26'-0"	27'-0"
	mm	5,385	5,486	5,791	6,172	6,146	6,248	6,477	6,782	6,604	6,705	7,010	7,391	7,518	7,620	7,925	8,230
E	ft-in	11'-6"	11'-6"	11'-6"	11'-6"	13'-6"	13'-6"	13'-6"	13'-6"	14'-6"	14'-6"	14'-6"	14'-6"	15'-6"	15'-6"	15'-6"	15'-6"
	mm	3,505	3,505	3,505	3,505	4,115	4,115	4,115	4,115	4,420	4,420	4,420	4,420	4,724	4,724	4,724	4,724
F	ft-in	13'-2"	13'-6"	14'-6"	16'-0"	16'-2"	16'-6"	17'-0"	18'-0"	16'-10"	17'-0"	18'-0"	19'-8"	18'-11"	19'-3"	20'-3"	21'-6"
	mm	4,013	4,115	4,420	4,877	4,927	5,029	5,182	5,486	5,080	5,182	5,486	5,944	5,766	5,867	6,172	6,553
G	ft-in	6'-0"	6'-0"	6'-0"	6'-0"	6'-0"	6'-0"	6'-0"	6'-0"	7'-0"	7'-0"	7'-0"	7'-0"	8'-0"	8'-0"	8'-0"	8'-0"
	mm	1,828	1,828	1,828	1,828	1,828	1,828	1,828	1,828	2,134	2,134	2,134	2,134	2,438	2,438	2,438	2,438

Tramac reserves the right to change or discontinue models and/or specifications without prior notice.

Boom Specifications

Model		TS14	TS16	TS18	TS20
Nom. Horizontal Reach (with hammer vertical)	ft	14'-0"	16'-0"	18'-0"	20'-0"
	m	4.3	4.9	5.5	6.1
Swing Arc	Deg	180°	180°	180°	180°
Max. Lifting Capacity (at boom nose, without hammer)	lbs	2,105	2,105	2,105	2,105
	kg	955	955	955	955
Weight (excluding hammer and Power Pack)	lbs	5,500	5,800	6,150	6,500
	kg	2,495	2,630	2,790	2,950
Static Overturning Moment (w/o hammer)	ft lbs	45,375	53,650	63,038	73,125
	Nm	61,520	72,740	85,468	99,144
Hammer Impact Class Range	ft lbs	750-2,000	750-2,000	750-2,000	750-2,000
	Nm	1,000-2,700	1,000-2,700	1,000-2,700	1,000-2,700

Breaker Specifications

Model		SC28	SC36	300	700
Impact Class	ft lbs	750	1000	1500	2000
Working Weight	lbs	595	805	1325	2105
	kg	270	365	600	955
Flow	gpm	10-20	14.5-26	21-33	21-37
Range	lpm	40-75	55-100	80-125	80-140
Striking Rate	max bpm	1420	1550	1025	885
Maximum Operating Pressure	psi	1740	1800	1740	2150
	bar	120	125	120	148
Tool Diameter	in	2.8	3	3.74	4.4
	mm	72	76	95	72
Overall Height w/ Standard Tool & Bracket	in	57	60	66	90.5
	mm	1446	1530	1675	2300

Dealer:

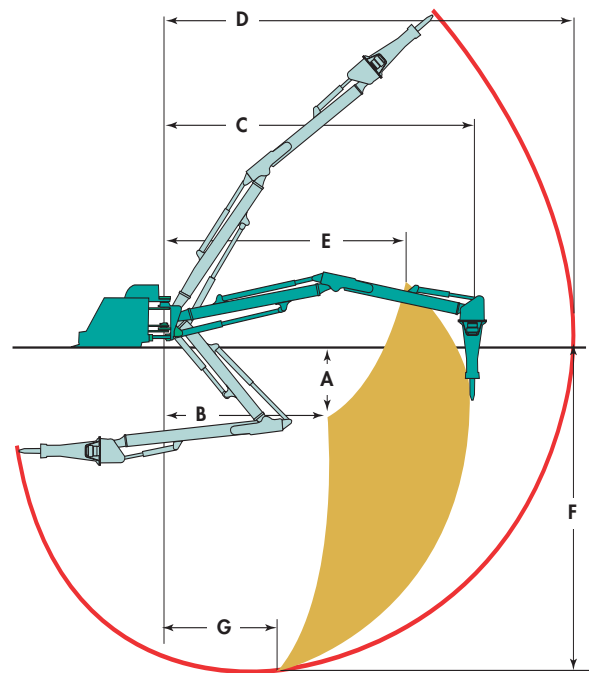

With Tramac TS Series Rockbreaker booms, you can count on...

- Reliability
- Increased production
- A safer environment
- Heavy-duty components for long life and minimal maintenance

USA: 12 Orben Drive, #3, Landing, NJ 07850 / 1-800-526-3837 / 1-973-770-4457 / FAX 1-973-770-0812
 Canada: 3421 boul. Industriel / Laval, QC / Canada H7L 4S3 / 1-888-663-8122 / 1-450-663-8122 / FAX 1-450-663-6797
 e-mail: sales@tramac.com http://www.tramac.com

