

Crusher/Pulverizer

PBH Series

for carriers from 40,000 to 100,000 lbs.



PBH Series Crusher/Pulverizer

Muscle Mate's PBH Crusher/Pulverizer: new speed valve develops a jaw closing time of 0.9 seconds for dramatic increase in production

The powerful PBH crusher/pulverizer uses a patented front breaker designed for rapid on-site processing of concrete. It is intended for use with carriers weighing between 40,000 and 100,000 lbs. **The PBH is designed to crush and pulverize concrete chunks ranging in thickness from 24" to 36" (depending on model), in a single action. It then shears and bundles the rebar, in preparation for hauling.**



● Faster cycle time

- New speed valve accepts high oil flow, maintains maximum speed during full cycle, including crushing stage

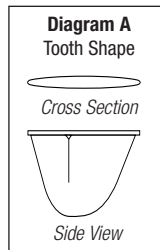

● Patented breaker tooth splits concrete

- Splitting force breaks concrete far better than crushing force
- Patented fin-shaped front tooth (Diagram A) needs 40% less power to crack material than traditional pyramidal or pointed teeth (Diagram B)
- Tooth is designed to exert constant force through the full closing arc of jaw

(Note: See reverse for diagram of complete crushing cycle.)

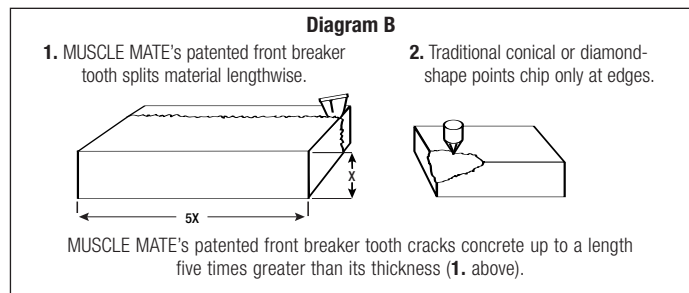

● Powerful crushing force

- Crushes concrete down to aggregate in a single jaw-closing action

● Light weight and easy to mount

- New high tensile steel reduces weight of crusher
- Fits on lighter carriers yet produces like a heavier unit
- Easy connection to carrier bucket linkage

● Built to last

- Mono-bloc frame of heavy duty, high alloy, abrasion-resistant steel
- Trunnion mounted cylinder for uniform power during closing arc

For dimensions and specifications, see the back of this page.

PBH Series Crusher/Pulverizer

Specifications and Dimensions

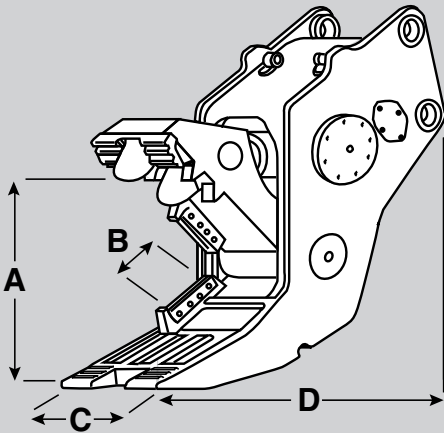

PBH Crusher/Pulverizer Specifications		690	890	990	1090	1190
Working Weight	<i>lbs</i> <i>kg</i>	2865 1300	3640 1650	5512 2500	6615 3000	7720 3500
Carrier Weight	<i>US tons</i>	20-35	35-40	35-40	35-45	45-50
Crushing Force (Measured at front tooth)	<i>US tons</i>	64	84	100	127	127
Operating Pressure	<i>psi</i> <i>bar</i>	4550 314	4550 314	4550 314	4550 314	4550 314
← A →	<i>inches</i> <i>mm</i>	33.5 850	34 860	39 989	37 940	49 1250
← B →	<i>inches</i> <i>mm</i>	5.5 140	5.5 140	11 280	11 280	11 280
← C →	<i>inches</i> <i>mm</i>	20 500	21 530	26 670	26 660	26 660
← D →	<i>inches</i> <i>mm</i>	68 1730	78 1978	84 2145	96.5 2452	100 2543

TRAMAC CORPORATON reserves the right to change or discontinue models and/or specifications without prior notice.

The 4-stage operating cycle of MUSCLE MATE's PBH Crusher/Pulverizer

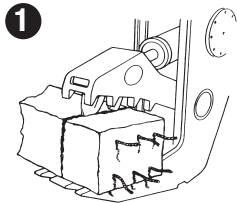

Stage 1. Concrete is first split into two large pieces by Muscle Mate's patented, fin-shaped breaker teeth.

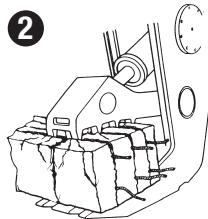

Stage 2. Next, the split concrete is broken into six sections by the powerful side teeth.

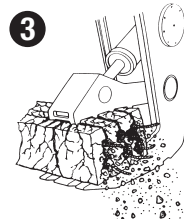

Stage 3. The transversely broken concrete is crushed and broken further by a sliding action between the fixed arm and the face of the crusher arm.



Stage 4. Finally, the material is pulverized into small aggregate, separated from the rebar, then sheared to manageable size by the unit's integral cutting blades.

Dealer:

Quality and dependability: two features you can count on with every MUSCLE MATE product.

All MUSCLE MATE products are engineered for superior performance, manufactured to the most exacting specifications, and—within the guidelines of the industry's most rigid quality control program—thoroughly inspected at every stage of production. All working parts are precision-machined to the closest tolerances, and all materials meet or exceed the highest industry standards. These are but a few of the many vital reasons major contractors worldwide choose our products. *They know that with MUSCLE MATE, reliability is crucial; a basic component we conscientiously build into every unit that bears our name.*



Muscle Mate is a Tramac Corporation brand.

USA: 12 Orben Drive #3 / Landing, NJ 07850 / 1-800-526-3837 / 1-973-770-4457 / FAX 1-973-770-0812
Canada: 3421 boul. Industriel / Laval, QC / Canada H7L 4S3 / 1-888-663-8122 / 1-450-663-8122 / FAX 1-450-663-6797
 e-mail: sales@tramac.com <http://www.tramac.com>